

Multichannel Analog to MIDI Converter IC

MANMIDI11-1.02

mm@zenprobe.com

The chip can be used in one of two modes selected using the MODE pin. In MODE0 4 channels of analog conversion are available. In MODE1 11 channels are available by using an inexpensive external multiplexer IC. Control pins are available for setting output bit resolution and blanking time following each message send. This is useful for limiting the MIDI rate, eg to reduce processing costs in the receiver. Note that most modern synths and sequencers allow the user to remap controllers to different numbers.

MODE0 notes

1. The analog inputs ANx produce proportional MIDI output on MIDI channel 0 using controllers 0-3
2. The upper supply rail range is from 4 to 6v.
3. An analog input equal to the supply will produce a MIDI output of 127.
4. The control pins RESx set the output resolution as follows: (pins float high when disconnected)

RES1	RES0	MIDI Bits
L	L	4
L	H	5
H	L	6
H	H	7

eg: For highest accuracy set RES0=RES1=H

5. The control pins BTx set the blank time:

BT1	BT0	Time (ms)
L	L	0.6
L	H	2.5
H	L	5.1
H	H	10.1

eg: For best response time set
BT0 = BT1 = L

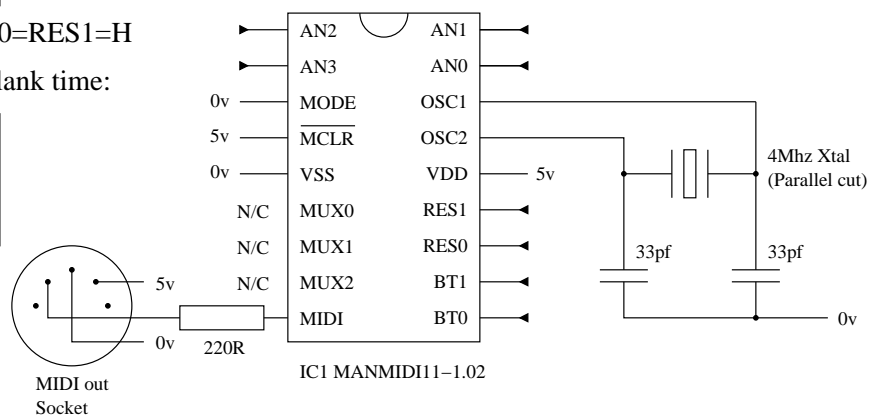

MODE1 notes

1. The multiplexer inputs S0-S7 map to MIDI controller outputs 0-7. AN1, AN2, AN3 map to controllers 8,9,10.
2. The upper range for inputs is VDD.
3. The control pins RESx and BTx have the same behaviour as in MODE0.
4. IC2 can be replaced with any similar multiplexer eg DG408 (different pinout).

